

Technical data	operation when directly connected to chimney	operation when connected accumulation mass	
Energy label	A	A	A
<b>Operating data</b>			
Nominal heat power	9 kW	----	----
Efficiency	> 80 %	----	----
Consumption of wood	2,6 kg/h	4 kg	3,5 kg
Total heat output of the burning chamber	----	16 kW	14 kW
Average heat output / heat accumulation time <sup>5</sup>	----	1,6 kW / 8 h	1,4 kW / 8 h
Mass flow of flue gas	9 g/s	13 g/s	12 g/s
Required chimney pressure	12 Pa	12 Pa	15 Pa
Required amount of combustion air	25 m <sup>3</sup> /h	35 m <sup>3</sup> /h	30 m <sup>3</sup> /h
<b>Average flue gas temperature</b>			
on the output	280 °C	350 °C	333 °C
behind 2,5 m of ceramic accumulation system KMS 240 <sup>1</sup>	----	208 °C	----
behind S-accumulation rings (5x S-acc. ring Ø345mm)	----	----	217 °C
<b>Heat distribution</b>			
fireplace insert	60–70 %	37 %	37 %
door glass (single / double)	40 / 30 %	40 / 30 %	40 / 30 %
additional accumulation mass	----	23–33 %	23–33 %
<b>Information for ventilated builds</b>			
Minimal grill area supply / outgoing	800 / 900 cm <sup>2</sup>	800 / 900 cm <sup>2</sup>	800 / 900 cm <sup>2</sup>
Minimum distance from insulated areas / floor	50 / 0 mm	50 / 0 mm	
Reference insulation <sup>2</sup> ceiling / back wall / side wall / floor	120 / 80 / 80 / 0 mm	120 / 80 / 80 / 0 mm	
Calciumsilicate insulation <sup>3</sup> ceiling / back wall / side wall / floor	90 / 60 / 60 / 0 mm	90 / 60 / 60 / 0 mm	
<b>Information for non-ventilated builds (closed grills)</b>			
Minimum radiant area <sup>4</sup>	suitable	3,5 m <sup>2</sup>	
Minimum distance from insulated areas / floor	50 / 20 mm	50 / 20 mm	
Reference insulation <sup>2</sup> ceiling / back wall / side wall / floor	160 / 100 / 100 / 20 mm	160 / 100 / 100 / 20 mm	
Calciumsilicate insulation <sup>3</sup> ceiling / back wall / side wall / floor	120 / 75 / 75 / 20 mm	120 / 75 / 75 / 20 mm	
<b>General technical information</b>			
Total weight / lining weight	circa 280 / 70 kg	circa 280 / 70 kg	
Burning chamber dimensions (width x depth)	650 x 210 mm		
Combustion air connection	Ø 125 mm		
Use in non-ventilated accumulation builds according to craft rules	suitable		
Tested according to	EN 13229		
Meets values	1. BImSchV (Stufe2), 15a BVG		

1 Listed value from testing. For accurate results is evaluation of each system in the Ortnr / KOV program necessary

2 Mineral wool according to AGI-Q 132

3 Example SkamoEnclosure Board 225 kg/m<sup>3</sup>

4 Depends on accumulation period and material characteristics. Listed values calculated with average specific heat output = approx. 500 W/m<sup>2</sup>

5 Storage operation, one wood charge for storage duration, with closed construction and efficiency > 80%

## ECKA 80/35/50SLh small instalation dimensions left liftdoor

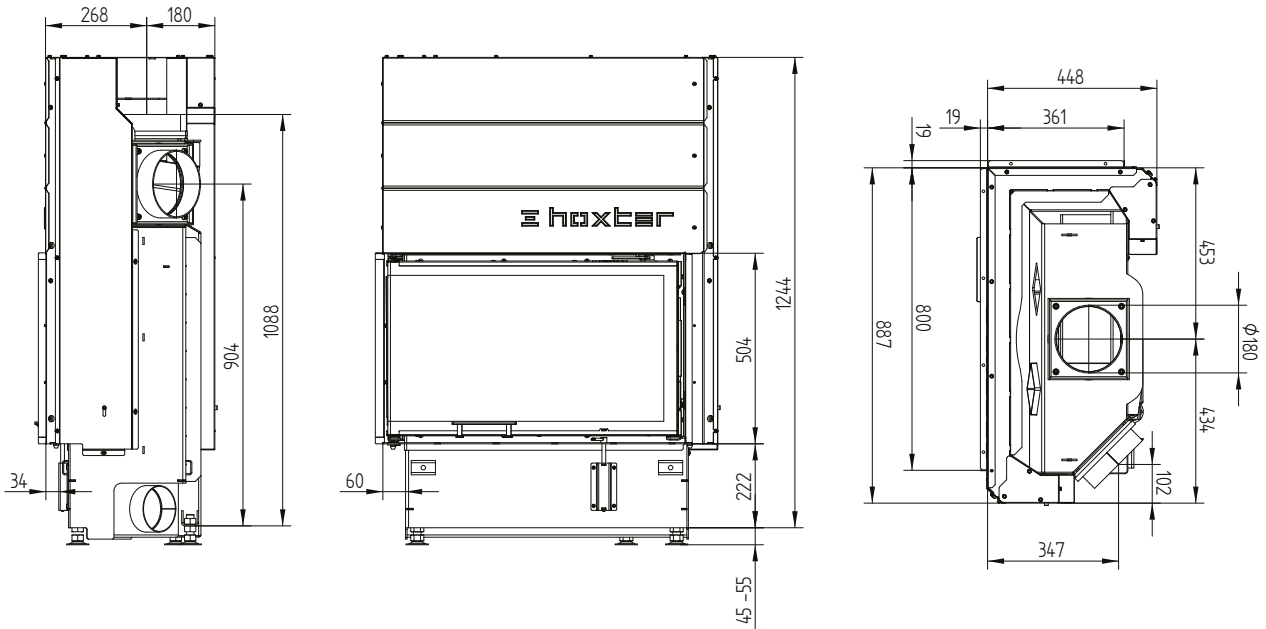

## ECKA 80/35/50Sh small instalation dimensions left liftdoor S-accumulation set

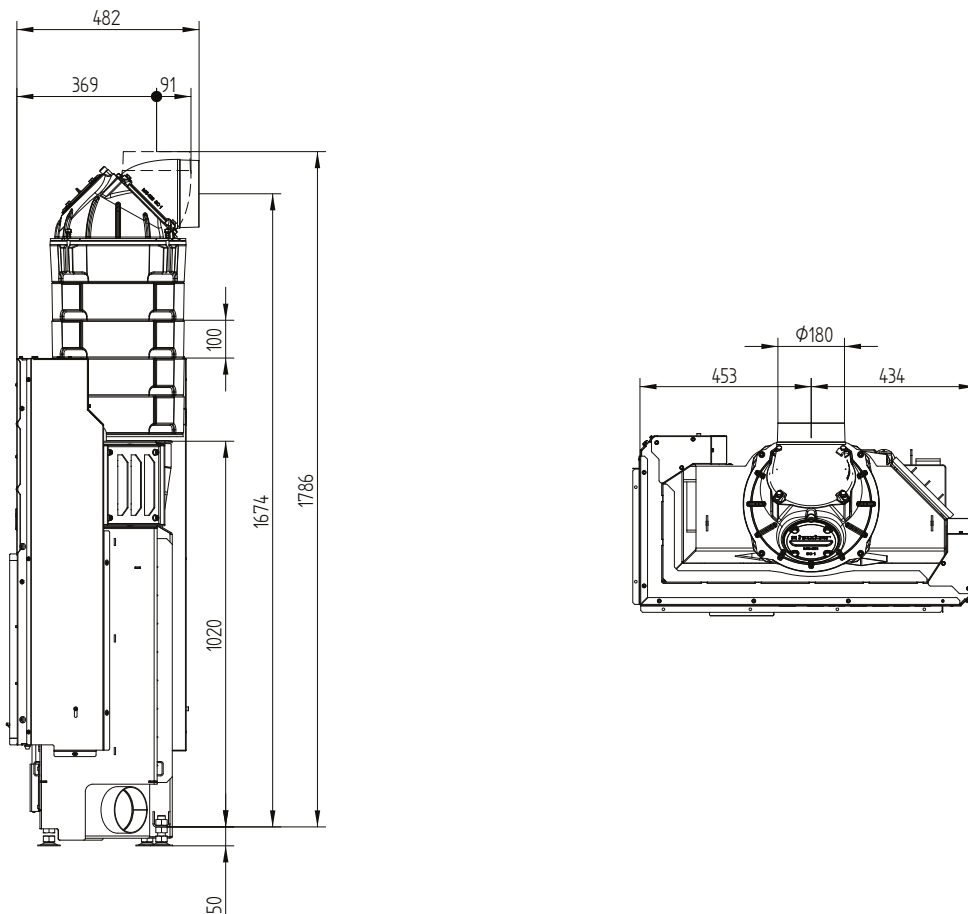

# ECKA 80/35/50SLh

Technical data  
Version 09/2023

Cover frame 80/35/50Lh left liftdoor 6sides 60 mm 1 x 90° / air inlet

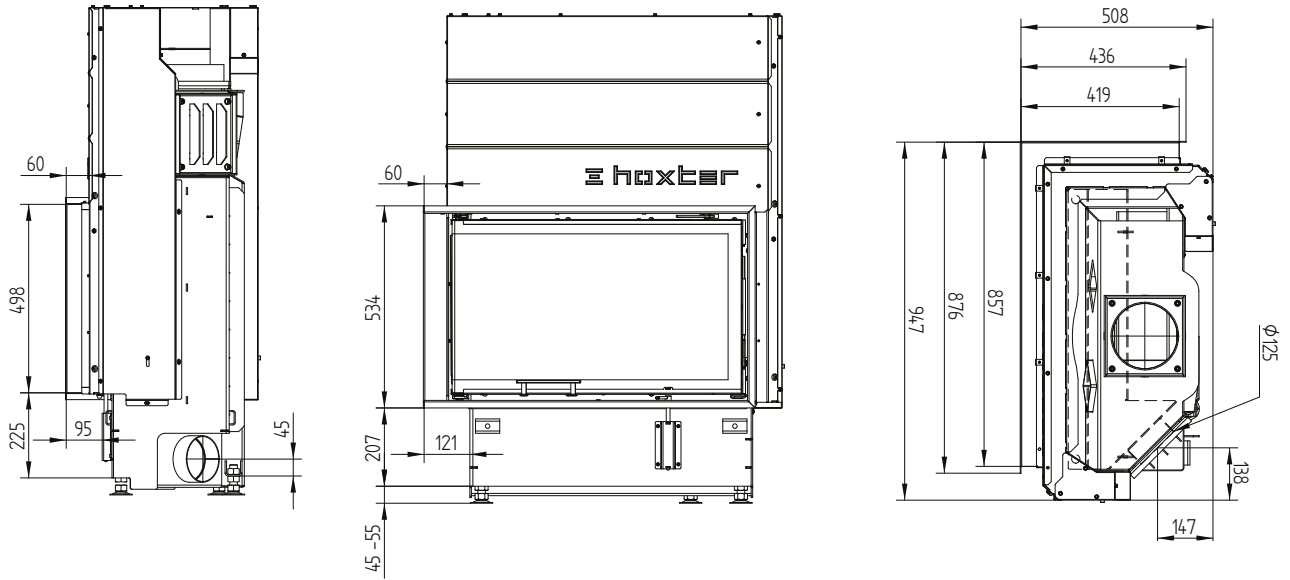

Cover frame 80/35/50Lh left liftdoor 4sides 60 mm 1 x 90°

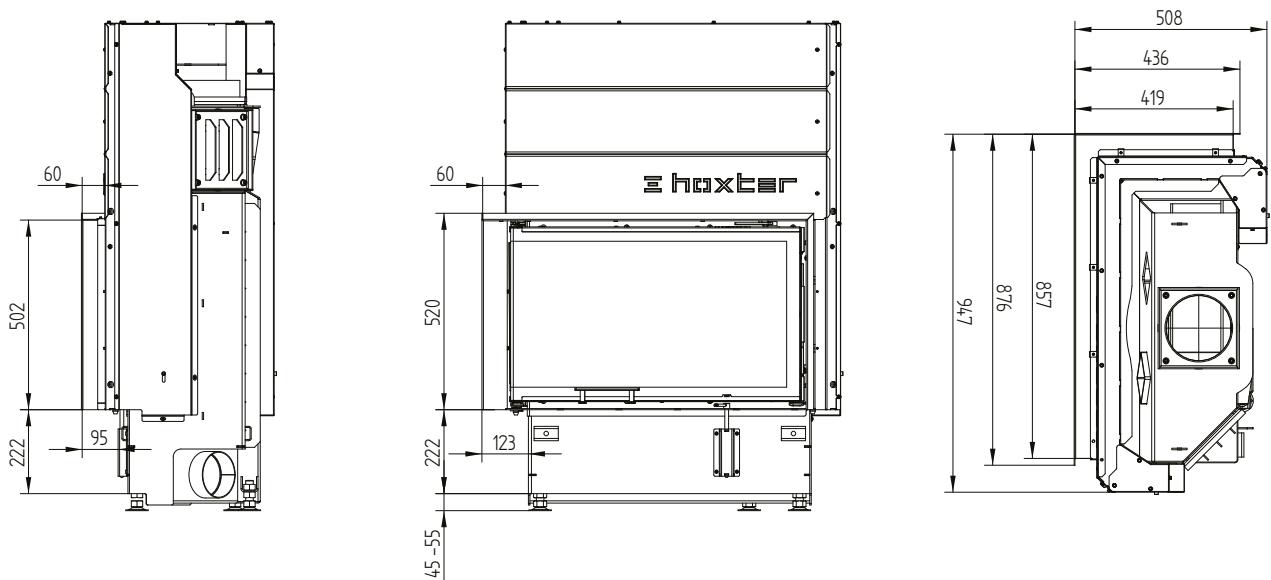

# ECKA 80/35/50SLh

Technical data  
Version 09/2023

## Build-on frame 80/35/50Lh left liftdoor 6sides 50 mm / feet

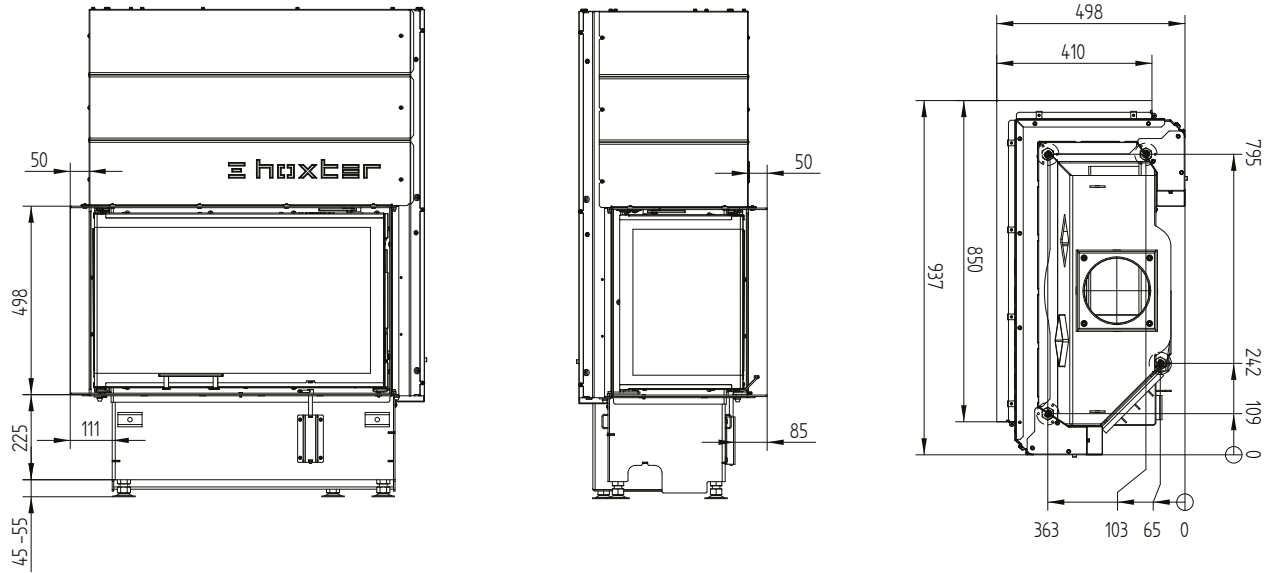

## Build-on frame 80/35/50Lh left liftdoor 6sides 80 mm

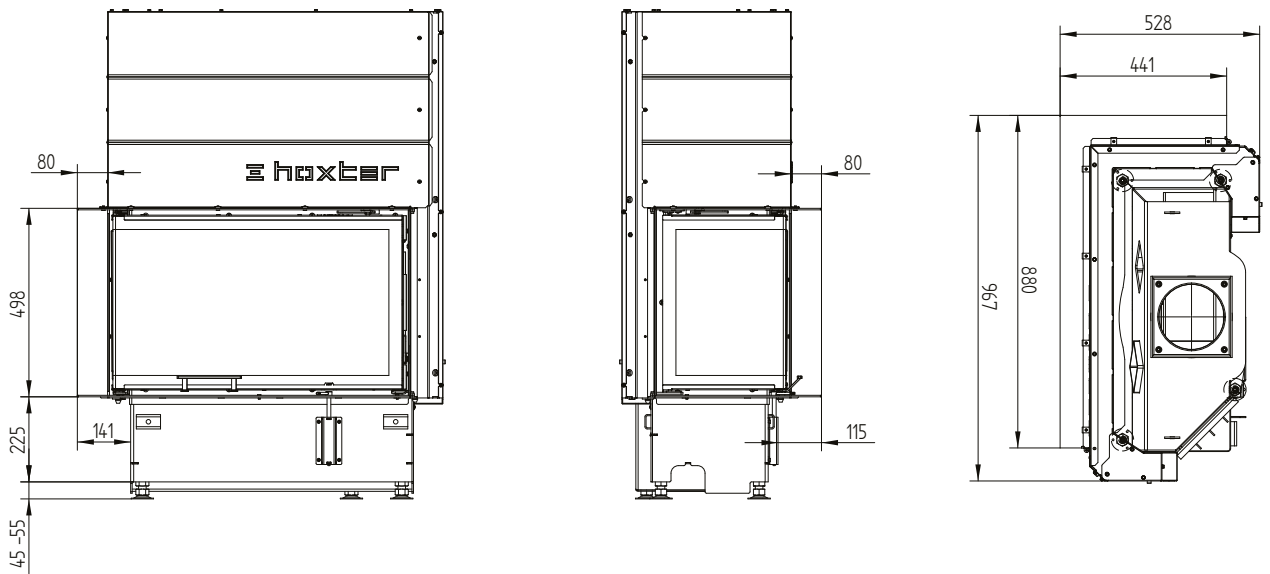



# ECKA 80/35/50SLh

Technical data  
Version 09/2023

## Build-on frame 80/35/50Lh left liftdoor 4sides 80 mm

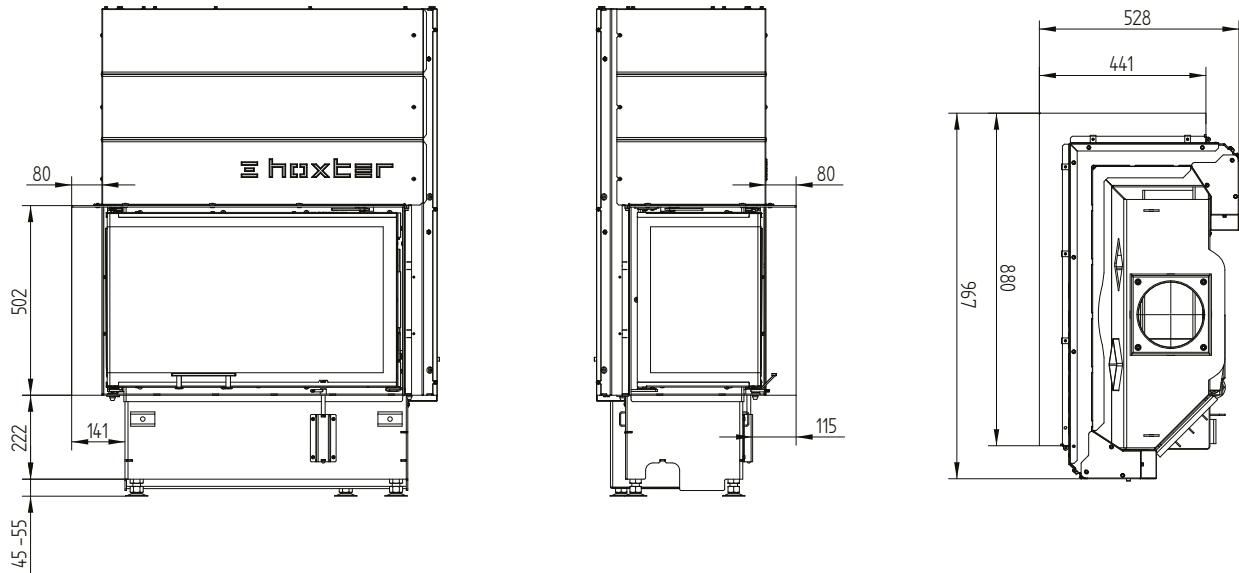

Technical data	operation when directly connected to chimney	operation when connected accumulation mass	
Energy label	A	A	A
<b>Operating data</b>			
Nominal heat power	9 kW	----	----
Efficiency	> 80 %	----	----
Consumption of wood	2,6 kg/h	4 kg	3,5 kg
Total heat output of the burning chamber	----	16 kW	14 kW
Average heat output / heat accumulation time <sup>5</sup>	----	1,6 kW / 8 h	1,4 kW / 8 h
Mass flow of flue gas	9 g/s	13 g/s	12 g/s
Required chimney pressure	12 Pa	12 Pa	15 Pa
Required amount of combustion air	25 m <sup>3</sup> /h	35 m <sup>3</sup> /h	30 m <sup>3</sup> /h
<b>Average flue gas temperature</b>			
on the output	280 °C	350 °C	333 °C
behind 2,5 m of ceramic accumulation system KMS 240 <sup>1</sup>	----	208 °C	----
behind S-accumulation rings (5x S-acc. ring Ø345mm)	----	----	217 °C
<b>Heat distribution</b>			
fireplace insert	60–70 %	37 %	37 %
door glass (single / double)	40 / 30 %	40 / 30 %	40 / 30 %
additional accumulation mass	----	23–33 %	23–33 %
<b>Information for ventilated builds</b>			
Minimal grill area supply / outgoing	800 / 900 cm <sup>2</sup>	800 / 900 cm <sup>2</sup>	800 / 900 cm <sup>2</sup>
Minimum distance from insulated areas / floor	50 / 0 mm	50 / 0 mm	
Reference insulation <sup>2</sup> ceiling / back wall / side wall / floor	120 / 80 / 80 / 0 mm	120 / 80 / 80 / 0 mm	
Calciumsilicate insulation <sup>3</sup> ceiling / back wall / side wall / floor	90 / 60 / 60 / 0 mm	90 / 60 / 60 / 0 mm	
<b>Information for non-ventilated builds (closed grills)</b>			
Minimum radiant area <sup>4</sup>	suitable	3,5 m <sup>2</sup>	
Minimum distance from insulated areas / floor	50 / 20 mm	50 / 20 mm	
Reference insulation <sup>2</sup> ceiling / back wall / side wall / floor	160 / 100 / 100 / 20 mm	160 / 100 / 100 / 20 mm	
Calciumsilicate insulation <sup>3</sup> ceiling / back wall / side wall / floor	120 / 75 / 75 / 20 mm	120 / 75 / 75 / 20 mm	
<b>General technical information</b>			
Total weight / lining weight	circa 280 / 70 kg	circa 280 / 70 kg	
Burning chamber dimensions (width x depth)	650 x 210 mm		
Combustion air connection	Ø 125 mm		
Use in non-ventilated accumulation builds according to craft rules	suitable		
Tested according to	EN 13229		
Meets values	1. BImSchV (Stufe2), 15a BVG		

1 Listed value from testing. For accurate results is evaluation of each system in the Ortnr / KOV program necessary

2 Mineral wool according to AGI-Q 132

3 Example SkamoEnclosure Board 225 kg/m<sup>3</sup>

4 Depends on accumulation period and material characteristics. Listed values calculated with average specific heat output = approx. 500 W/m<sup>2</sup>

5 Storage operation, one wood charge for storage duration, with closed construction and efficiency > 80%

## ECKA 80/35/50SRh small instalation dimensions right liftdoor

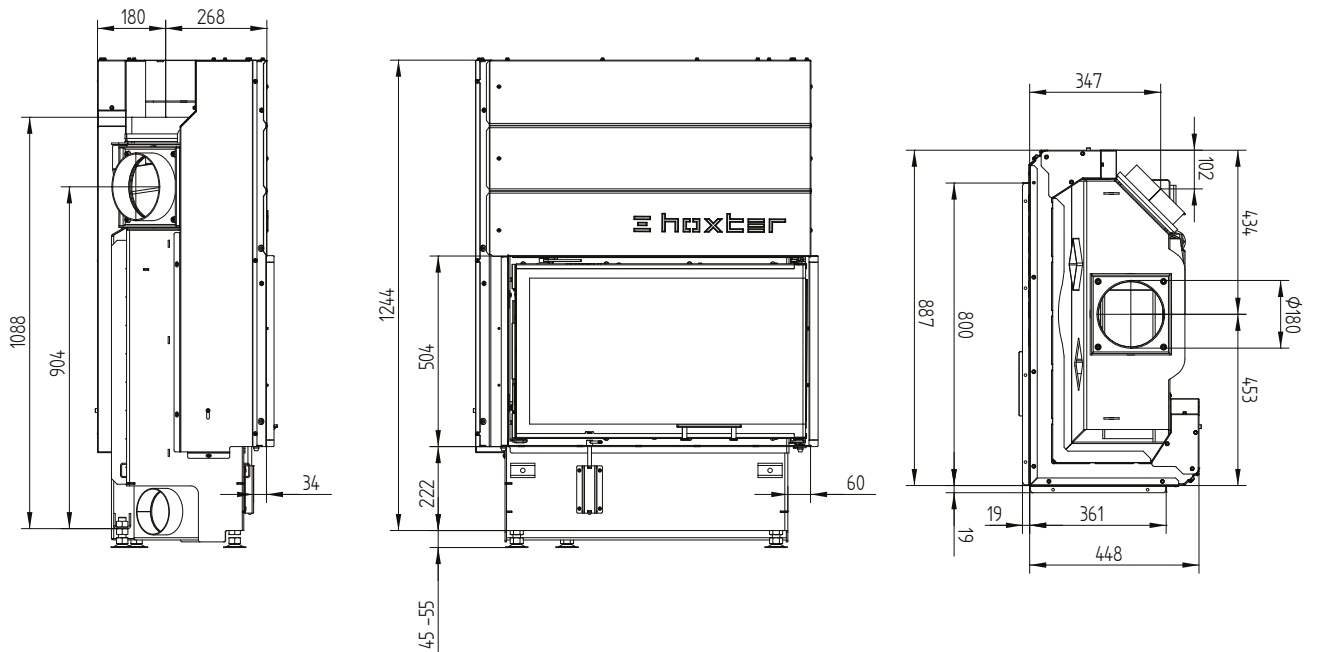

## ECKA 80/35/50SRh small instalation dimensions right liftdoor S-accumulation set

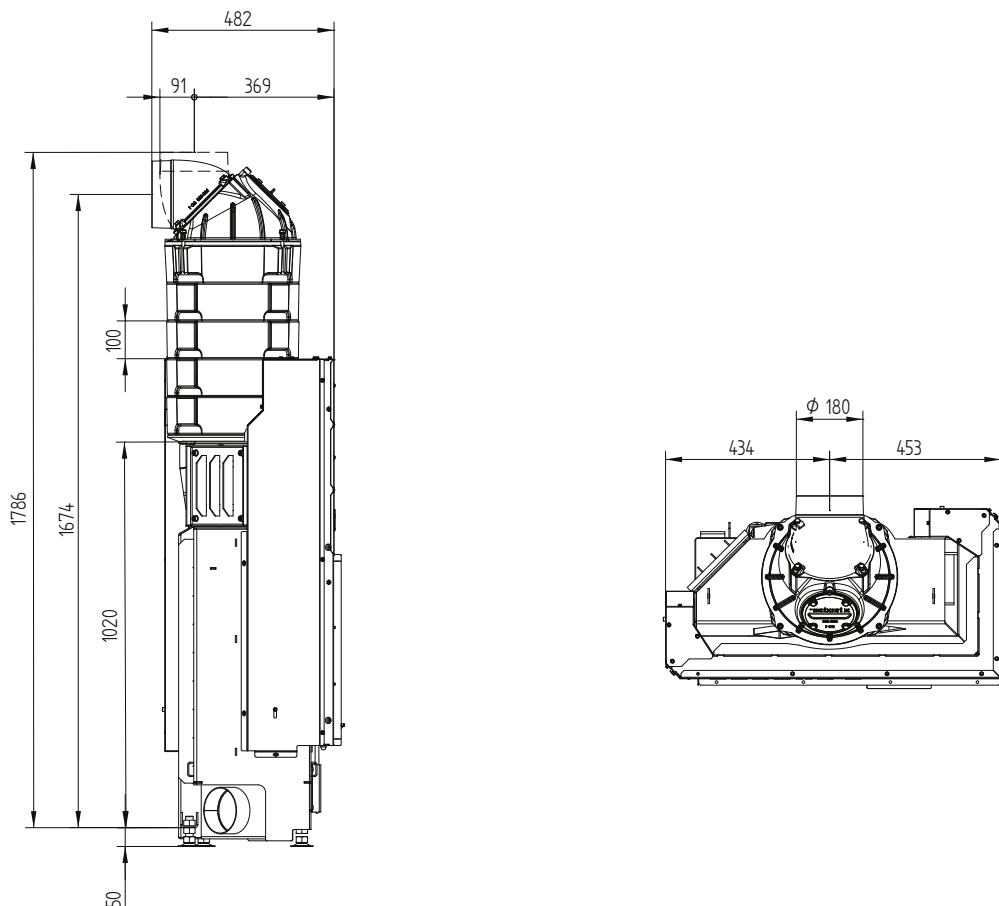

# ECKA 80/35/50SRh

Technical data  
Version 09/2023

## Cover frame 80/35/50Rh right liftdoor 6sides 60 mm 1 x 90° / air inlet

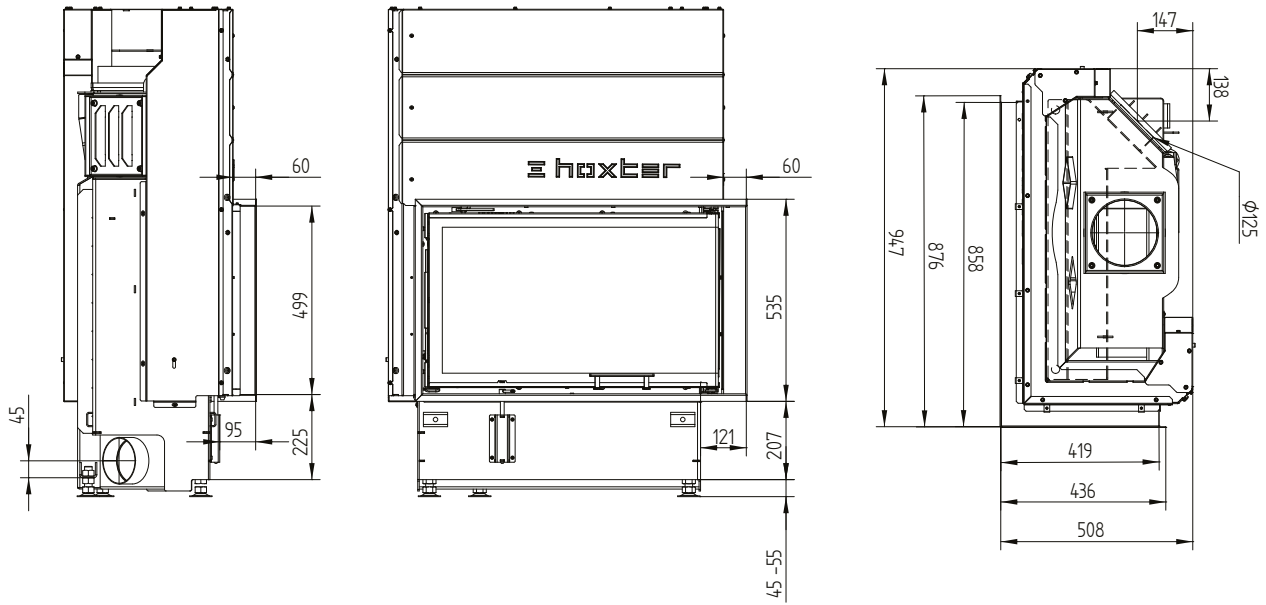

## Cover frame 80/35/50Rh right liftdoor 4sides 60 mm 1 x 90°

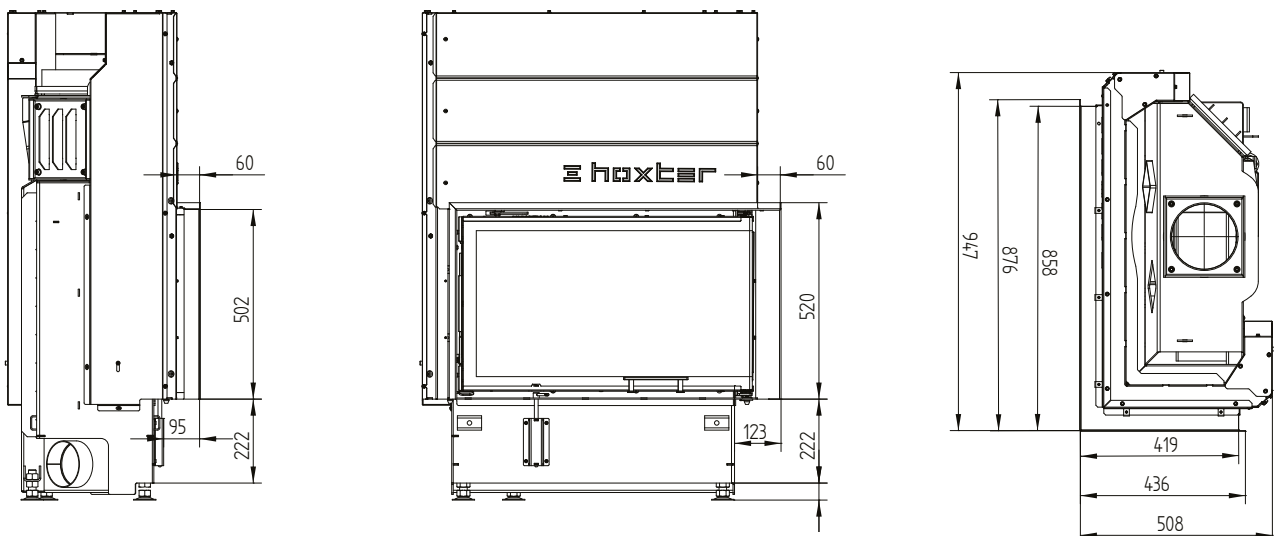

# ECKA 80/35/50SRh

Technical data  
Version 09/2023

## Build-on frame 80/35/50Rh right liftdoor 6sides 50 mm / feet

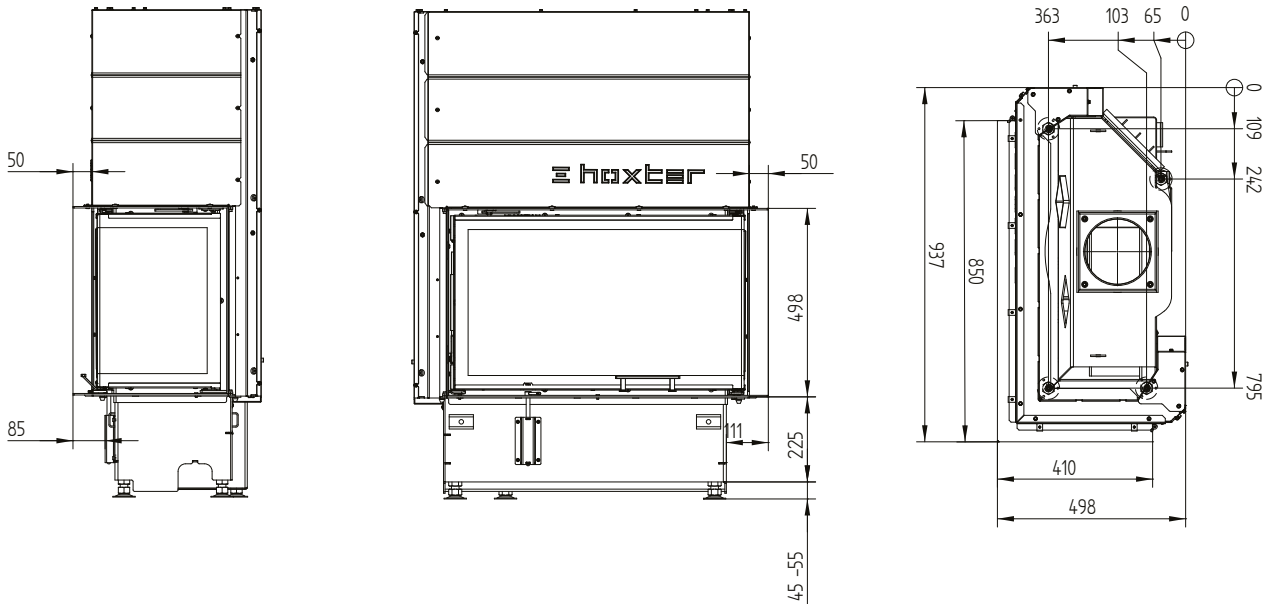

## Build-on frame 80/35/50Rh right liftdoor 6sides 80 mm

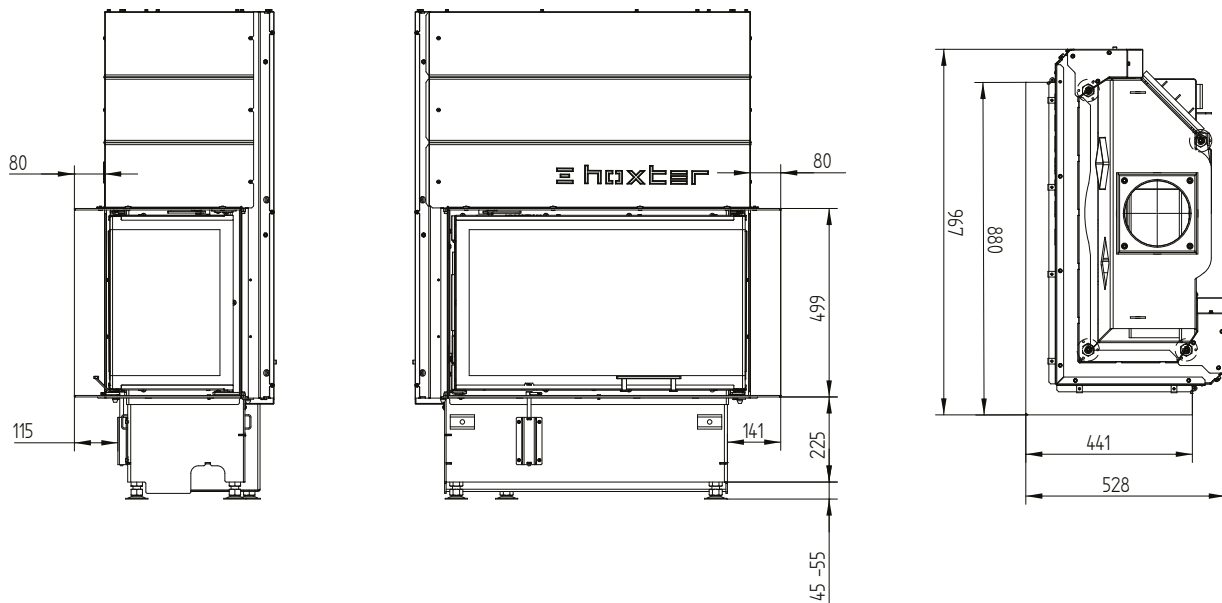

# ECKA 80/35/50SRh

Technical data  
Version 09/2023

Build-on frame 80/35/50Rh right liftdoor 4sides 80 mm

