

HAKA 37/50W WTR

Technical data

	operation when directly connected to chimney	
	HAKA 37/50W	HAKA 37/50WI
Energy label	A+	A+
Operating data		
Nominal heat power / Power absorbed to water	8 / 5,6 kW	8 / 6,4 kW
Efficiency	> 80 %	> 80 %
Consumption of wood	2,2 kg/h	2,2 kg/h
Mass flow of flue gas	6,7 g/s	6,7 g/s
Required chimney pressure	12 Pa	12 Pa
Required amount of combustion air	20 m³/h	20 m³/h
Average flue gas temperature		
on the output	184 °C	184 °C
Heat distribution		
fireplace insert	16 %	6 %
door glass (single / double)	0 / 14 %	0 / 14 %
water	70 %	80 %
Water exchanger specifications		
Maximum working pressure	2,5 bar	2,5 bar
Minimum return water temperature	60 °C	60 °C
Water capacity	47 liters	47 liters
Connection input / output	1" / 1"	1" / 1"
Information for builds		
Minimal grill area supply / outgoing (with vent. grill)	250 / 300 cm²	200 / 250 cm²
Minimum radiant area ³ (without vent. grill)	suitable	suitable
Minimum distance from insulated areas / floor	40 / 0 mm	20 / 0 mm
Reference insulation ¹ ceiling / back wall / side wall / floor	80 / 40 / 40 / 0 mm	80 / 40 / 40 / 0 mm
Calciumsilicate insulation ² ceiling / back wall / side wall / floor	60 / 25 / 25 / 0 mm	60 / 25 / 25 / 0 mm
General technical information		
Total weight / lining weight	circa 199 / 57 kg	circa 206 / 57 kg
Burning chamber dimensions (width x depth)	305 x 305 mm	
Combustion air connection	Ø 125 mm	
Use in non-ventilated accumulation builds according to craft rules	suitable ⁴	
Tested according to	EN 13229	
Meets values	1. BImSchV (Stufe2), 15a BVG	

HAKA 37/50W

Nr.	Thread size	Description
1	G 1" (AG)	Water supply from heating system - min. 60°C
2	G 1" (AG)	Hot water supply to heating system
3	G 1/2" (AG)	Water supply from the waterlines into the cooling loop
4	G 1/2" (AG)	Discharge of water from the cooling loop into the waste
5	G 3/8" (IG)	Pocket for air vent valve
6	G 1/2" (IG)	Pocket for thermal sensors

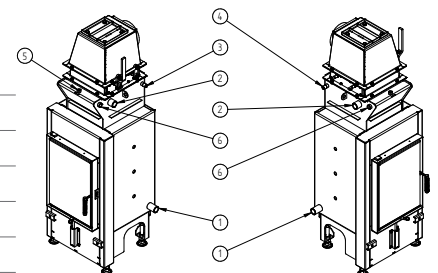

1 Mineral wool according to AGI-Q 132

2 Example SkamoEnclosure Board 225 kg/m³

3 Depends on accumulation period and material characteristics. Listed values calculated with average specific heat output = approx. 500 W/m²

4 With regard to the inspection capability and maximum ambient temperatures of the external switching devices (e.g. TAS/SV)

HAKA 37/50W WTR

HAKA 37/50W / air inlet / feet

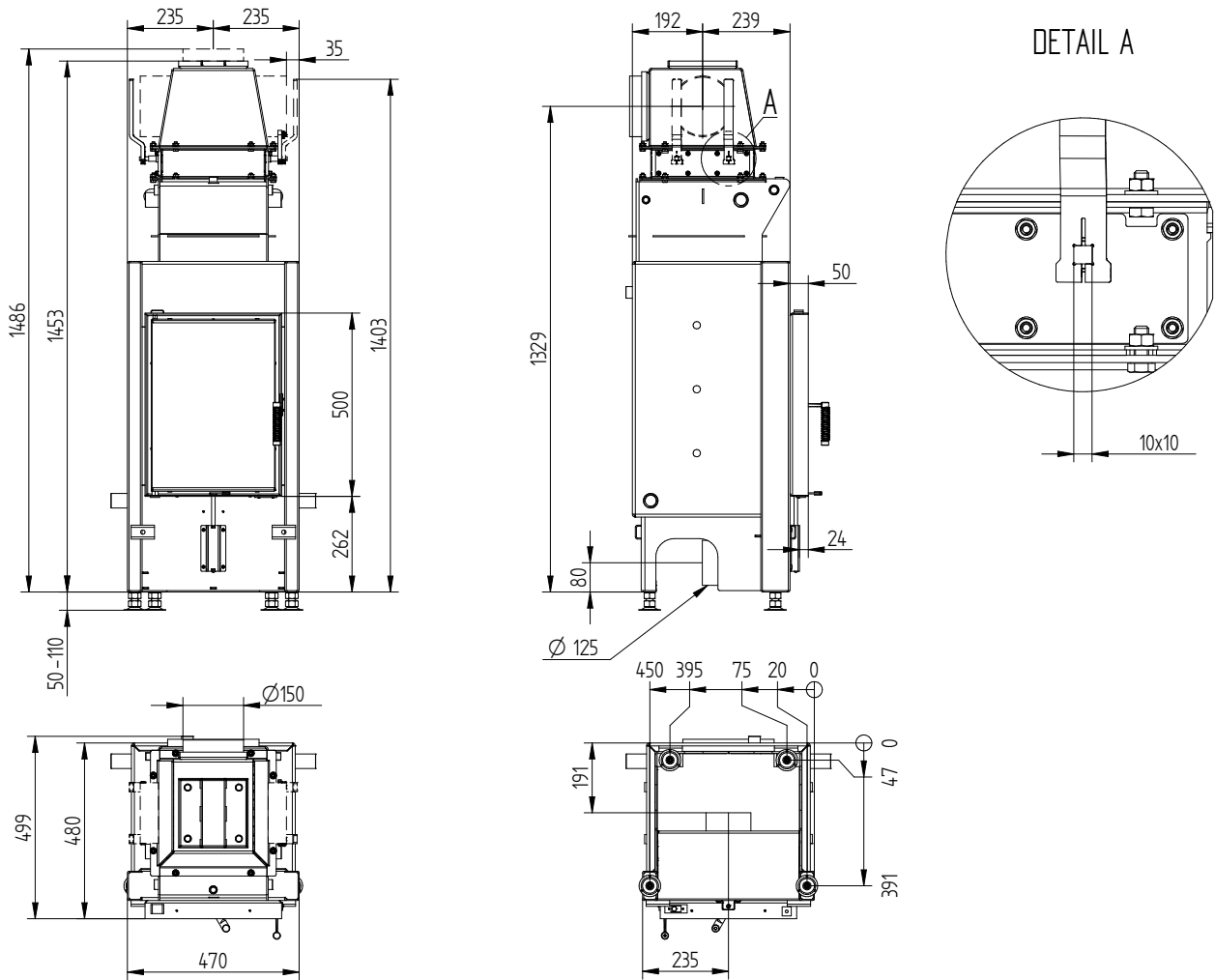

HAKA 37/50W WTR

HAKA 37/50WI / air inlet / feet

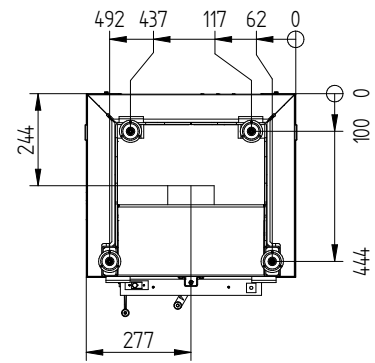
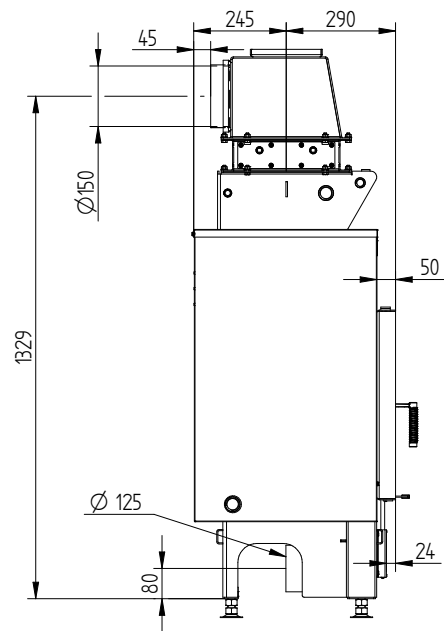
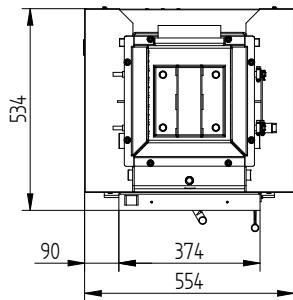
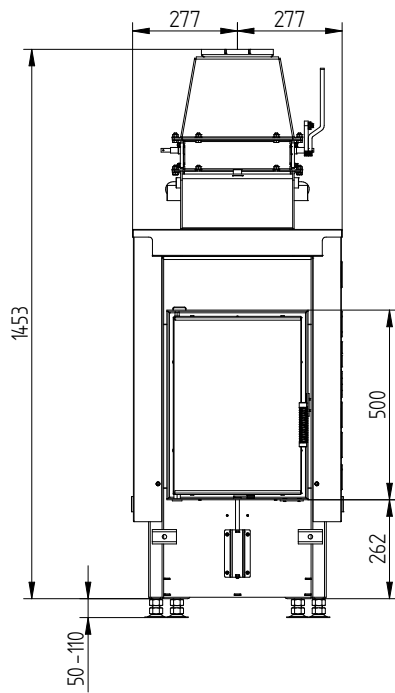

HAKA 37/50W WTR

Cover frame 37/50 4sides 50 mm 1 x 90°

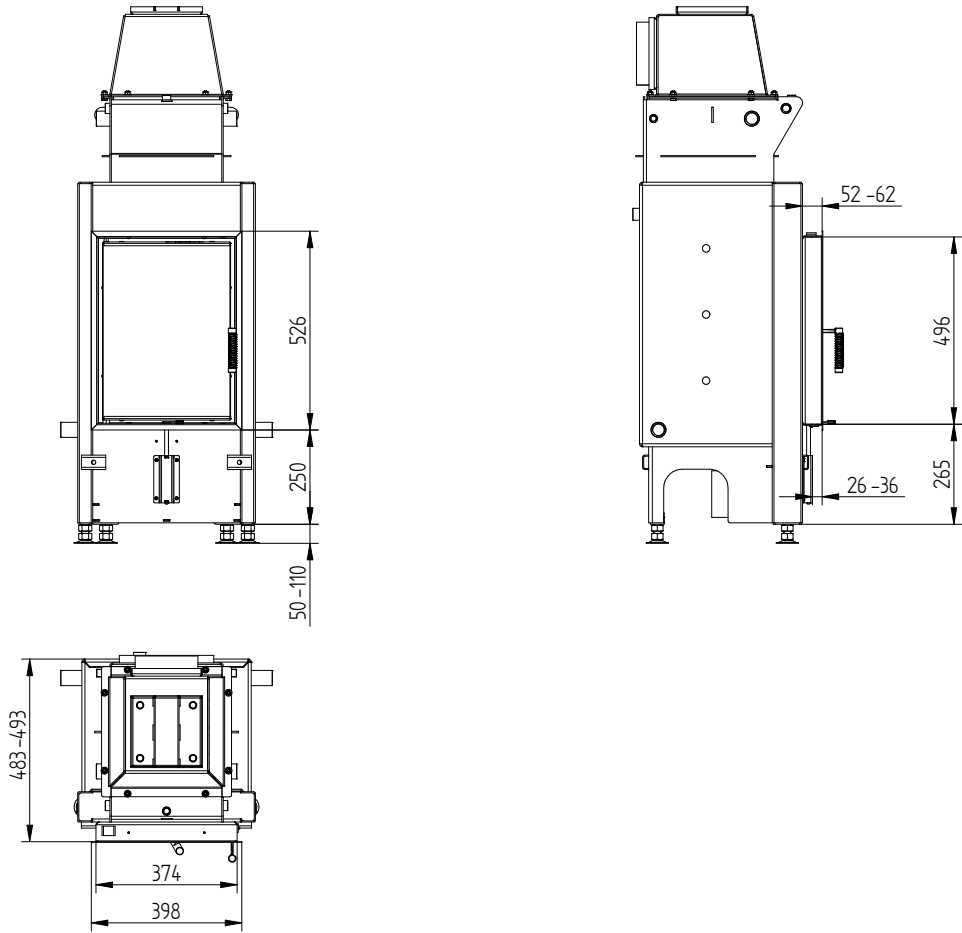

HAKA 37/50W WTR

Cover frame 37/50 4sides 80 mm 2 x 45°

